

ROTATING RIGHT

MODEL 80T-3 SINGLE ACTING TRIPLEX PUMP



80T-3

A 80 horsepower 3" stroke horizontal triplex single acting plunger pump. Available in nickel-aluminum-bronze fluid end material at pump speeds up to 500 RPM and four accessory gear reduction unit ratios.

Power End Features:

- Heavy-duty, tapered roller crankshaft bearings
- Precision type, aluminum alloy crankpin bearings
- Aluminum connecting rods
- Alloy steel crosshead pins
- Bronze bearing crosshead pin bushings
- Alloy steel crankshaft with ground journals and polished throws
- Cast iron power frame
- Bronze bearing crosshead pin bushings
- Cast iron crossheads with upper/lower oil grooves
- Replaceable Stainless Steel intermediate rods
- Flooded sump, splash distribution lubrication
- Rated rod load is 6336 lbs

Fluid End Features:

- 17-4 Stainless Steel or Nickel Aluminum Bronze Steel stuffing boxes (Includes nuts)
- Plungers-Ceramic or Tungsten Carbide coated
- General Service, Molded Lip or Aramid Fiber plunger packing
- Mission Spherical suction and discharge valves
- Valve Seat & Valve Body: Nitronic 50
- Spring: Inconel
- Severe duty valves with inserts available

80T-3 Triplex Plunger Pump

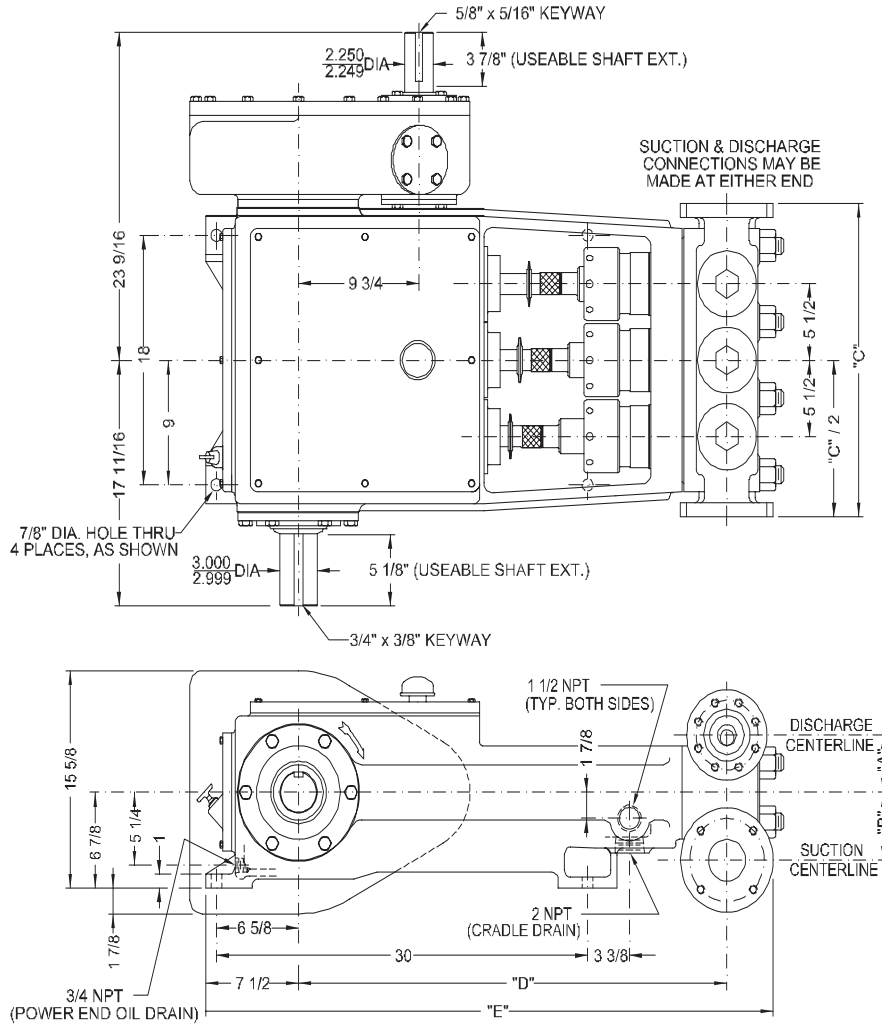

Specifications

Pump Size

(maximum plunger size x stroke length in.(mm))
 3 3/8 x 3 (85.7 x 76.2)

Rated bhp at 500 rpm (kw): 80 (59.65)

Rated plunger load, pounds(Kg): 6336 (2874)

Maximum discharge pressure: psi(kPa)

"L" model: 2016 (13,901)

"M" model: 4267 (29,420)

"H" model: 5161 (35,598)

Crankshaft extension: in.(mm)

Diameter: 3 (76.2)

Length long side: 5 1/8 (130.2)

Length short side: 5 1/8 (130.2)

Keyway (width x depth):

3/4 x 3/8 (19.1 x 9.5)

Maximum recommended sheave in.(mm): 37.5 (952.5)

Minimum recommended sheave in.(mm): 20 (508)

For larger sizes: **Contact Factory**

Pinion shaft extension,

if gear reducer is supplied in.(mm)

For belt or chain drive: **Contact Factory**

For direct drive: Diameter: 2 1/4 (57.2)

Length: 3 7/8 (98.4)

Keyway (width x depth):

5/8 x 5/16 (15.9 x 7.9)

Accessory gear reduction unit ratios:

2.34:1, 2.77:1, 3.03:1, 3.5:1

Oil Capacity, gallons (L)

Crankcase: 2 (7.6)

Gear Reducer: 1 (3.8)

Weight, pump only on

wood shipping skids pounds (Kg):

1195 (542.0)

Gear reducer, approximate pounds (Kg):

315 (142.88)

Pump Type	Flange Connections		Dimensions in inches (mm)				
	Discharge Connection Sizes	Suction Connection Sizes	A	B	C	D	E
80T-3L(Flanged)	2 (50.8) API-2000 RJ	3 (76.2) ANSI-150 FF	4 1/8	4 7/8	22 1/2	34 5/8	45 7/8
80T-3L(Threaded)	2 (50.8) N.P.T.	3 (76.2) N.P.T.	4 1/8	4 7/8	20 1/2	34 5/8	44 3/4
80T-3M	1 1/2 (38.1) API-5000 RJ	2 1/2 (63.5) ANSI-150 FF	4	4 1/2	22 1/4	34 5/8	44 3/4
80T-3H	1 1/4 (31.8) ANSI-2500 RJ	2 1/2 (63.5) ANSI-300 FF	4	4 1/2	22 5/8	34 5/8	45 7/8

80T-3 Triplex Plunger Pump

Performance Data

PUMP	English Units					200 RPM		300 RPM		350 RPM		400 RPM		450 RPM		500 RPM	
	Plunger Dia. In.	Plunger Area Sq. In.	BPD per RPM	GPM per RPM	Max. Press. PSI	BPD	GPM	BPD	GPM	BPD	GPM	BPD	GPM	BPD	GPM	BPD	GPM
80T-3L	3.375	8.9462	11.9503	0.3486	708	2391	69.7	3586	104.6	4183	122.0	4781	139.4	5378	156.8	5976	174.3
	3.250	8.2958	11.0815	0.3232	764	2217	64.6	3325	97.0	3879	113.1	4433	129.3	4987	145.4	5541	161.6
	3.000	7.0686	9.4423	0.2754	896	1889	55.1	2833	82.6	3305	96.4	3777	110.2	4250	123.9	4722	137.7
	2.750	5.9396	7.9341	0.2314	1067	1587	46.3	2381	69.4	2777	81.0	3174	92.6	3571	104.1	3968	115.7
	2.500	4.9087	6.5571	0.1912	1500	1312	38.2	1968	57.4	2295	66.9	2623	76.5	2951	86.1	3279	95.6
	2.250	3.9761	5.3113	0.1549	1594	1063	31.0	1594	46.5	1859	54.2	2125	62.0	2391	69.7	2656	77.5
	2.000	3.1416	4.1966	0.1224	2017	840	24.5	1259	36.7	1469	42.8	1679	49.0	1889	55.1	2099	61.2
80T-3M	2.000	3.1416	4.1966	0.1224	2017	840	24.5	1259	36.7	1469	42.8	1679	49.0	1889	55.1	2099	61.2
	1.750	2.4053	3.2130	0.0937	2634	643	18.7	964	28.1	1125	32.8	1286	37.5	1446	42.2	1607	46.9
	1.625	2.0739	2.7704	0.0808	3055	555	16.2	832	24.2	970	28.3	1109	32.3	1247	36.4	1386	40.4
	1.500	1.7671	2.3606	0.0688	3584	473	13.8	709	20.7	827	24.1	945	27.5	1063	31.0	1181	34.4
	1.375	1.4849	1.9835	0.0579	4267	397	11.6	596	17.4	695	20.2	794	23.1	893	26.0	992	28.9
80T-3H	1.375	1.4849	1.9835	0.0579	4267	397	11.6	596	17.4	695	20.2	794	23.1	893	26.0	992	28.9
	1.250	1.2272	1.6393	0.0478	5161	328	9.6	492	14.3	574	16.7	656	19.1	738	21.5	820	23.9
Brake Horsepower Required						32.0		48.0		56.0		64		72		80	

PUMP	Metric Units					200 RPM		300 RPM		350 RPM		400 RPM		450 RPM		500 RPM	
	Plunger Dia. mm	Plunger Area cm ²	M ³ /Hr per RPM	L/Sec. per RPM	Max. Press. kPa	M ³ /Hr	L/Sec.	M ³ /Hr	L/Sec.	M ³ /Hr	L/Sec.	M ³ /Hr	L/Sec.	M ³ /Hr	L/Sec.	M ³ /Hr	L/Sec.
80T-3L	86	57.717	0.0792	0.0220	4883	15.83	4.40	23.75	6.60	27.70	7.70	31.66	8.80	35.62	9.90	39.58	11.00
	83	53.521	0.0734	0.0204	5266	14.68	4.08	22.02	6.12	25.69	7.14	29.36	8.16	33.03	9.18	36.70	10.20
	76	45.604	0.0625	0.0174	6180	12.51	3.47	18.76	5.21	21.89	6.08	25.02	6.95	28.14	7.82	31.27	8.69
	70	38.320	0.0526	0.0146	7355	10.51	2.92	15.77	4.38	18.39	5.11	21.02	5.84	23.65	6.57	26.28	7.30
	64	31.669	0.0434	0.0121	10342	8.69	2.41	13.03	3.62	15.20	4.22	17.37	4.83	19.54	5.43	21.72	6.03
	57	25.652	0.0352	0.0098	10987	7.04	1.95	10.55	2.93	12.31	3.42	14.07	3.91	15.83	4.40	17.59	4.89
	51	20.268	0.0278	0.0077	13906	5.56	1.54	8.34	2.32	9.73	2.70	11.12	3.09	12.51	3.47	13.90	3.86
80T-3M	51	20.268	0.0278	0.0077	13906	5.56	1.54	8.34	2.32	9.73	2.70	11.12	3.09	12.51	3.47	13.90	3.86
	44	15.518	0.0213	0.0059	18162	4.26	1.18	6.38	1.77	7.45	2.07	8.51	2.36	9.58	2.66	10.64	2.96
	41	13.380	0.0184	0.0051	21064	3.67	1.02	5.51	1.53	6.42	1.78	7.34	2.04	8.26	2.29	9.18	2.55
	38	11.401	0.0156	0.0043	24711	3.13	0.87	4.69	1.30	5.47	1.52	6.25	1.74	7.04	1.95	7.82	2.17
	35	9.580	0.0131	0.0036	29420	2.63	0.73	3.94	1.09	4.60	1.28	5.26	1.46	5.91	1.64	6.57	1.82
80T-3H	35	9.580	0.0131	0.0036	29420	2.63	0.73	3.94	1.09	4.60	1.28	5.26	1.46	5.91	1.64	6.57	1.82
	32	7.917	0.0109	0.0030	35584	2.17	0.60	3.26	0.90	3.80	1.06	4.34	1.21	4.89	1.36	5.43	1.51
Kilowatts Required						23.9		35.8		41.8		47.7		54		60	

Volumetric Rate is based on 100% Volumetric Efficiency. Brake Horsepower/Kilowatts Required is based on 90% Mechanical Efficiency. For operation below 200 RPM, auxiliary lubrication system required. Not all plunger sizes are shown. Contact National-Oilwell for additional information. 3-3/8 & 3-1/4" Plungers require spherical valves

The information and data on this sheet is accurate to the best of our knowledge and belief, but are intended for general information only. Applications suggested for the materials are described only to help readers make their own evaluations and decisions, and are neither guarantees nor to be construed as express or implied warranties of suitability for these or other applications. National Oilwell makes no warranty either express or implied beyond that stipulated in National Oilwell Standard Terms and Conditions of Sale.

Accessories

Rotating Right offers a full line of accessories to ensure long trouble free and safe operation of your multiplex pumps.

Accessories Include:

- Pulsation Dampeners - Suction & Discharge
- Vibration Shock Switches
- Liquid Level Gauges & Switches
- Pressure Safety Valves
- Plunger Lubricators
- Fire Safety Valves
- High Discharge Pressure Switch
- Condensate Drain
- N.A.C.E. Valving
- Lubricator Level Controller
- API Valves
- Drive Options



Expendables



With our worldwide buying power Rotating Right is well equipped to provide a wide range of replacement parts & expendables for virtually all multiplex plunger pumps regardless of make or model.



Our expendables inventory includes plungers, packing, brass, valves, bearings, crankshafts, connecting rods and seals.



Repair & Overhauls

Rotating Right service technicians follow strict quality control procedures for every pump repair and overhaul. The use of consistent and reliable re-manufacturing techniques ensure your equipment is returned to you in "Like New" condition.

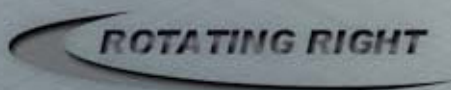
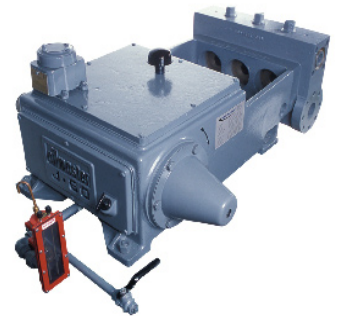

Head Office:
6120 Davies Road
Edmonton, AB
T6E 4M9

Phone: (780) 485-2010 • Toll Free: (866) 707-7867
Fax: (780) 485-1938
• Calgary • Drayton Valley • Lloydminster
www.rotatingright.com