

ROTATING RIGHT

1 HIGH 12, 18, 22, 28 & 36 ROUND CARTRIDGE HOUSINGS

Rotating Right Inc. offers ASME standard filter vessels that accept nearly all commercially available filter cartridges.

With years of experience providing our customers with expertise in all types of filtration as well as engineering and fabrication capabilities we can satisfy all your filtration requirements.

Whenever you have special filtration requirements, consult our sales department for quick, economical solutions for your application.



Standard Features:

- Housings available in carbon steel, 316 stainless steel and other materials
- Pressure ratings in 100, 125, and 150 psi
- Clean and dirty drain port connections
- Variety of O-ring seals
- ASME code stamp available on selected models
- Flanged or threaded connection options on smaller units
- Covers are o-ring sealed and easy to remove
- Adjustable leg assembly

Our Commercial and Industrial cartridge housings are manufactured of carbon steel, stainless steel & and available in other exotic materials engineered for filtration applications involving: chemical systems, general pre-filtration, high-purity water & final product purification.

Modified version of the Industrial Housings available for cost-sensitive applications.

Housings available from 3 round to 36 round and from 1 high to 4 high

Sanitary & NSF models available

Cartridges available in most materials and micron ratings

CRN AVAILABLE FOR MOST MODELS

1-HIGH INDUSTRIAL CARTRIDGE FILTERS

DESIGN PARAMETERS: FLOW BASED ON 5 USGPM/10" HIGH CARTRIDGE

MATERIAL OF CONSTRUCTION: CARBON STEEL, STAINLESS STEEL AND OTHER EXOTIC MATERIALS

STAINLESS STEEL : GLASS BEAD INSIDE AND OUTSIDE

CARBON STEEL : EXTERNAL SURFACE PAINTED WITH ENAMEL

MODEL NO.	VESSEL DIA (PIPE) (INCHES)	INLET OUTLET (INCHES)	NUMBER OF ELEMENTS	HEIGHT OF ELEMENTS (INCHES)	A (INCHES)	B (INCHES)	C (INCHES)	D (INCHES)	MAX FLOW (USGPM)	WEIGHT (LBS)
12RX1H	12.75	1.5	12	10	11	11	19	37	60	173
18RX1H	14	2	18	10	12	12	19	38	90	222
22RX1H	16	2	22	10	12	12	19	38	110	264
28RX1H	18	3	28	10	13	12	21	41	140	341
36RX1H	20	3	36	10	14	12	22	42	180	389

DESIGN PARAMETERS:

DESIGN PRESSURE : 150 PSIG

DESIGN TEMPERATURE : 225° F

CARTRIDGE TYPES AVAILABLE:

STANDARD:

DOUBLE OPEN ENDED
WITH SPRING SEAL
NO POST.

OPTION :

DOUBLE OPEN END WITH
POSITIVE TIE DOWN.
O-RING # 222
O-RING #226 WITH LOCKING
TABS

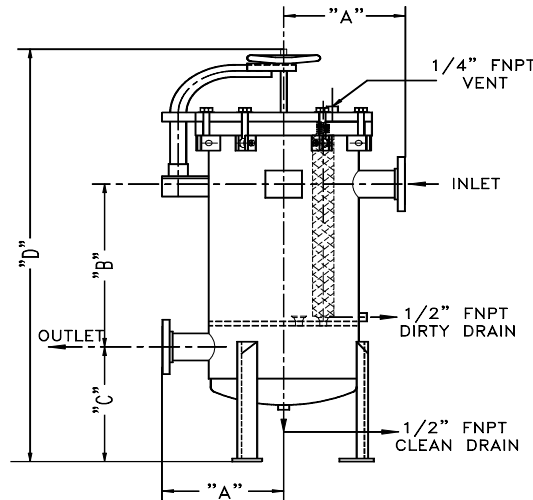

Head Office:
6120 Davies Road
Edmonton, AB
T6E 4M9

Phone: (780) 485-2010 • Toll Free: (866) 707-7867

Fax: (780) 485-1938

• Calgary • Drayton Valley • Lethbridge

www.rotatingright.com