

ROTATING RIGHT

## MYCLEX BAG FILTER SYSTEMS

### Mycelx P2 Hydrocarbon Removal Bag Filter

#### For Quick Knockdown of High Oil Concentrations

The Mycelx P2 Hydrocarbon Bag Filter has been engineered to remove free and separate phase oils from waste-streams. The P2 Bag Filter removes 85-95% of all oils in a single pass.

#### Technical Data:

- Flow rate: 1-20 gpm
- Pressure Required: 5 psi max.
- Gravity Flow Capable: Yes(up to 5 gpm)
- Availability: #2 Trade size bag filter Capacity: 15-45 lbs. of oil
- Fittings: 2" NPT Female
- Housing Material: 304 SS
- Bag Material: PP bag/ Perma Kleen filled
- **Easily fits where an oil/water separator won't**
- **Removes 85-95% of free oils in a single pass**
- **Increases life of all HRM polishing filters**



All HRM cartridges are engineered to remove hydrocarbons ranging from gasoline to oil from water in a single pass. HRM cartridges instantly solubilizes the PCB compounds and bonds them to its surface, keeping them from separating and emulsifying. HRM cartridges are also able to remove Sheen, Synthetic and Natural Oils, BTEX, PCBs, Chlorinated Solvents, and organically bound metals

## Dimensions

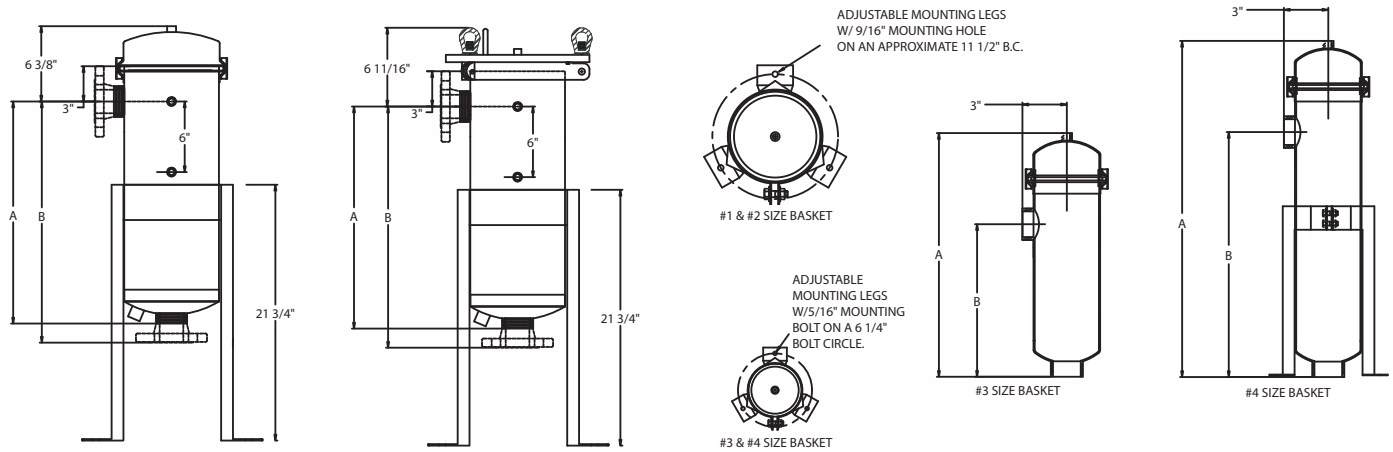

MODEL	DIM. A	DIM. B
#1 SIZE	18 7/8"	20 1/2"
#2 SIZE	34 7/8"	36 1/2"

MODEL	DIM. A	DIM. B
#3 SIZE	16 9/16"	10 3/8"
#4 SIZE	22 7/8"	16 11/16"

### ORDERING GUIDE #1 and #2 Sizes

BFS - 2		C	- 2 -		316	- 2	E
Product Code	Size	Closure	Connection	Material Options	Style	Gaskets	
BFS = Stainless Steel BFC = Carbon Steel	1 = 7x18 2 = 7x32	C = Clamp SB = Swing Bolt	2 = 2" FNPT 2F = 2" RFF 3 = 3" FNPT 3F = 3" RFF 2TC = 2" TC	Blank = 304 316 = 316 SS 134 = *3M 134 Coating over 304 SS	Blank = Side in, Bottom out 2 = Side in, Side out	Blank = Buna E = EPR S = Silicone V = Viton T = Teflon	

\*Note: 134 coating must have swing bolt closure and flanged connections.

### ORDERING GUIDE #3 and #4 Sizes

BFS - 4		C	- 1 -		2	E
Product Code	Size	Closure	Connection	Material	Style	Gaskets
BFS = Stainless Steel	3 = 4x8 4 = 4x14	C = Clamp	75 = 3/4" FNPT 1 = 1" FNPT 1.5 = 1 1/2" FNPT	Blank = 316 SS	Blank = Side in, Bottom out 2 = Side in, Side out (Hold down spring recommended)	Blank = Buna E = EPR S = Silicone V = Viton T = Teflon



**Head Office:**  
6120 Davies Road  
Edmonton, AB  
T6E 4M9

Phone: (780) 485-2010 • Toll Free: (866) 707-7867  
Fax: (780) 485-1938  
• Calgary • Drayton Valley • Lethbridge  
[www.rotatingright.com](http://www.rotatingright.com)